

**How to Use as an
OHMMETER**

CAUTION

Make certain no voltage is present in circuit before connecting ohmmeter to circuit. The ohmmeter is fused to help protect against misapplication of voltage but under certain conditions it is still possible to damage the meter and/or obtain incorrect readings.

1. Insert both red and black voltage leads into voltage receptacles at bottom of instrument. See Fig. 3.
2. Move rotary switch to either of two ohms range position.
3. With both leads far apart (not touching), pointer should line up with the division marked "∞" on ohms scale.
4. With test leads shorted or touching, line up pointer with "0" mark on ohms scale by turning zero adjust knob. See Fig. 4.

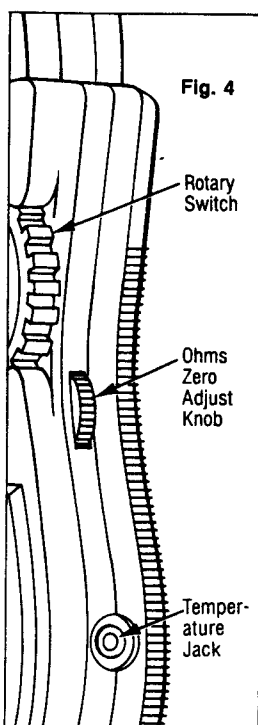

NOTE: If turning ohmmeter zero adjust knob does not line up pointer on zero mark replace battery and/or fuse. (See page 6 for fuse and battery information).

**How to Use as a
THERMOMETER**

1. Move rotary switch to Temperature position (X100) and keep switch at this position for all temperature measurements.
2. With both leads inserted, short leads together and zero adjust by moving knob. If this is not possible then change fuse or battery.
3. Remove voltage leads and insert temperature probe. See Fig. 4. Use an RBT-11P, RBT-12P or RBT-13P depending on medium. (See page 6 for probe information).

NOTE: Do not move zero adjust knob after initially zeroing. If knob is turned it will result in incorrect temperature or ohms readings.

**ACCESSORIES
Used with FS-3, FS-3C**

Description	Model
Fuse - 0.5 Amps	8AG-361.5
Battery - 1 "AA"	S915
Immersion Probe	RBT-11P
Universal Probe	RBT-12P
Vented Probe	RBT-13P
Carrying Case	"L"
Clip Leads	VL-11S
Replacement Tips for VL-11S	PT

SERVICE

Manufacturing number is die stamped in upper left hand corner of the scale plate.

For factory service, package instrument and packing slip with sufficient cushioning material in a shipping carton; make certain your name and address also appear on box as well as packing slip; ship prepaid via U.P.S. (where available) or Air Parcel Post insured to:

Service Division
AMPROBE INSTRUMENT
630 Merrick Road (Use for U.P.S.)
P.O. Box 329 (Use for Parcel Post)
Lynbrook, NY 11563-0329

Outside the U.S.A. the local Amprobe representative will assist you.

OPERATING INSTRUCTIONS

for

AMPROBE®

**Volt • Amp • Ohm • Temperature
FLAT SCALE CLAMP-ONS**

Model FS-3 (Fahrenheit Scale)

and

Model FS-3C (Centigrade Scale)

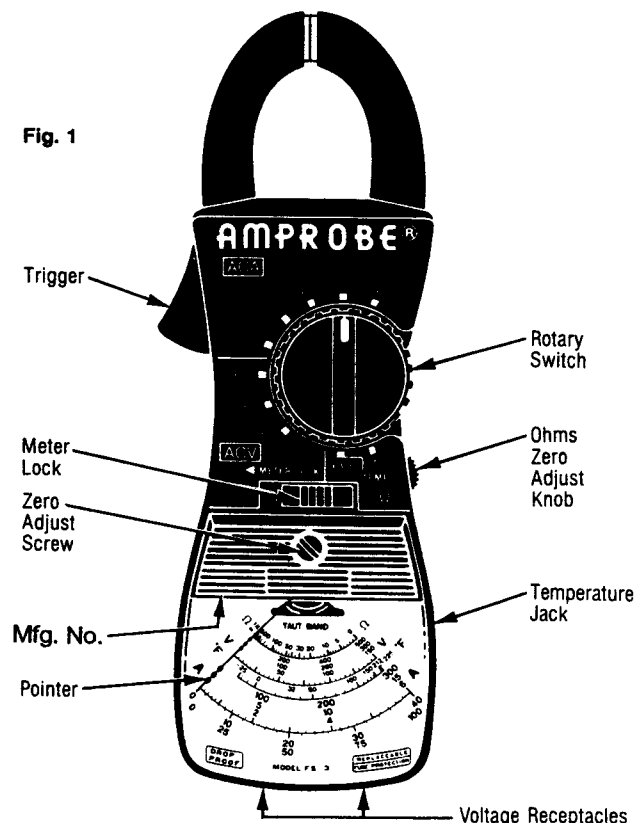

See "PRECAUTIONS FOR PERSONAL AND INSTRUMENT PROTECTION" on Page 2

See "LIMITED WARRANTY" on Page 2

AMPROBE INSTRUMENT®
A UNITED DOMINION COMPANY, LYNBROOK, NEW YORK 11563

AMPROBE INSTRUMENT®
A UNITED DOMINION COMPANY, LYNBROOK, NEW YORK 11563

LIMITED WARRANTY

Congratulations! You are now the owner of an AMPROBE® instrument. It has been quality crafted according to quality standards and contains quality components and workmanship. This instrument has been inspected for proper operation of all of its functions. It has been tested by qualified factory technicians according to the long-established standards of AMPROBE INSTRUMENT.

Your AMPROBE instrument has a limited warranty against defective materials and/or workmanship for one year from the date of purchase provided that, in the opinion of the factory, the instrument has not been tampered with or taken apart.

Should your instrument fail due to defective materials, and/or workmanship during the one-year warranty period, return it along with a copy of your dated bill of sale which must identify instrument by model number and Mfg. number.

For your protection, please use the instrument as soon as possible. If damaged, or should the need arise to return your instrument, it must be securely wrapped (to prevent damage in transit) and sent prepaid via Air Parcel Post insured or UPS where available to:

Service Division
 AMPROBE INSTRUMENT
 630 Merrick Road (For U.P.S.)
 P.O. Box 329 (For P.P.)
 Lynbrook, NY 11563-0329

Outside the U.S.A. the local Amprobe representative will assist you. Above limited warranty covers repair and replacement of instrument only and no other obligation is stated or implied.

PRECAUTIONS FOR PERSONAL AND INSTRUMENT SAFETY

IMPORTANT:

1. Read these instructions thoroughly and follow them carefully.
2. In many instances you will be working with dangerous levels of voltage and/or current, therefore, it is important you avoid direct contact with any uninsulated, current-carrying surfaces. Appropriate insulating gloves and clothing should be worn.
3. Before connecting or disconnecting the voltmeter to or from the circuit to be tested, turn off all power to the circuit.
4. Before applying test leads to circuit under test, make certain that leads are plugged into proper jacks and switches are set to proper range and function.
5. Before using any electrical instruments or tester for actual testing, the unit should be checked on a low energy high impedance source. Do not use power distribution lines or any other high energy sources.
6. Make certain no voltage is present in circuit, before connecting ohmmeter to circuit.
7. The jaws of clamp-on instruments should not, under any circumstances, be used as a device to hold or hang the instrument. When using the instrument as a voltmeter or ohmmeter, never clamp the jaws around or on to a conductor box or anything else — conducting or non-conducting.

GENERAL

Models FS-3, FS-3C are supplied with a set of test leads (VL-11S) and an 0.5 Amp fuse. Temperature Probes and other accessories are available separately.

The Flat Scale Clamp-Ons FS-3, FS-3C are capable of measuring Volts, Amps, Ohms and Temperature. By turning the rotary switch to the particular area, any one of these functions can be selected. No separate attachment is necessary for ohms. Temperature measurements can easily be made by inserting probe in side of instrument housing. Refer to individual instructions for each function.

The ohmmeter of the FS-3, FS-3C uses an "AA" battery and an 0.5 amp 250 volt fuse. To replace either fuse or battery remove two screws on back case, slide case horizontally toward you and lift off. See Fig. 2. Replace with correct fuse. See page 6. Observe proper polarity when replacing battery.

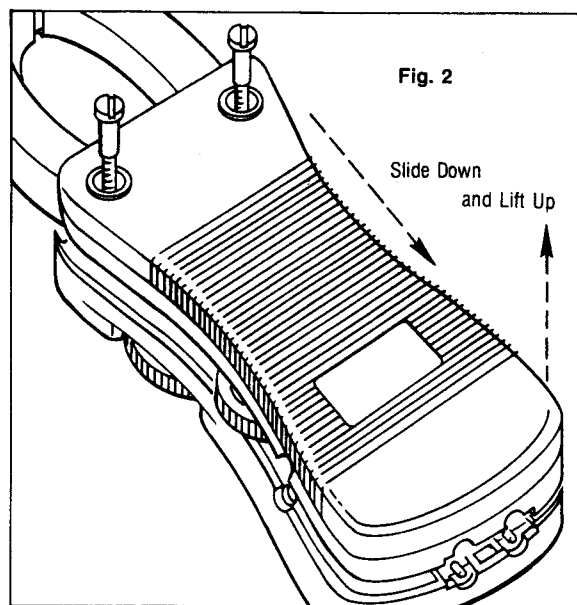

SPECIFICATIONS OF FS-3 & FS-3C

Functions: Volts AC, Amps AC, Ohms, Temperature

Ranges: 6, 15, 40, 100, 300 Amps
 150, 300, 600 Volts AC
 RX1 and RX100 Ohms with 25 Ohms midscale on RX1
 FS-3 - 25°F to 225°F
 FS-3C - 32°C to 107°C

Frequency: 50/60 HZ.

Accuracy: ± 3% of F.S. on Amps, Volts
 ± 3% of Scale Length Ohms, Temperature

Battery: 1 "AA"

Fuse: 0.5 Amps 250V - Fast blow

How to Take CURRENT READINGS

1. Make certain meter lock is in off position. See Fig. 1. Meter is free when button is pushed to the far right.
2. Make sure pointer is reading zero. For greater accuracy, the pointer should be set on the zero line. This is done by manually moving the zero adjust screw. See Fig. 1.
3. Turn rotary switch to highest current range if current to be measured is unknown.
4. Press trigger to open jaws.
5. Encircle conductor with transformer jaws.
6. Release trigger and be sure that jaws close properly before taking reading.
7. If reading is below half scale, move rotary switch to the next lower range. Keep moving rotary switch to lower ranges until pointer is indicating in the upper half of the scale.

How to Take VOLTAGE READINGS

IMPORTANT
 Read "PRECAUTIONS FOR PERSONAL AND INSTRUMENT SAFETY" before using instrument.

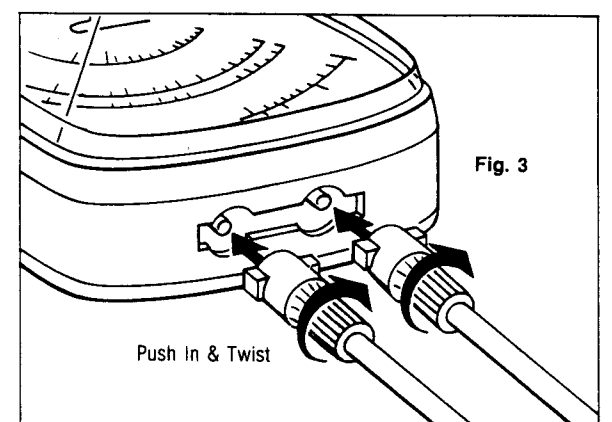

1. Insert bayonet type voltage test leads into voltage receptacles at bottom of instrument. Push against receptacle spring and twist to lock in place. See Fig. 3.
2. Turn rotary switch to highest voltage range if voltage to be measured is unknown.
3. Connect one alligator clip to one side of voltage to be measured. Then with meter in one hand touch the other side of voltage source with other lead. If reading is below half scale move rotary switch to the next lower range. Keep moving rotary switch to lower ranges until pointer is indicating in the upper half of the scale.