

Snap-on.

AC1000

DC Digital Clamp-on Connectionless Ammeter

OWNER'S MANUAL

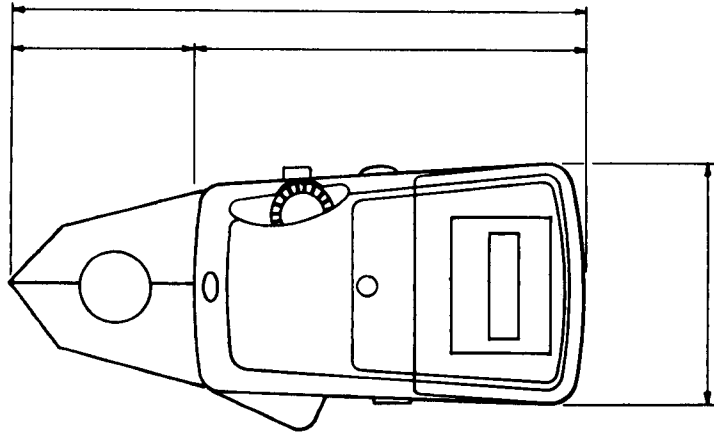

Limited Warranty and Repair/Exchange Policy

This instrument is designed and produced to provide unlimited service. Should it become inoperative after the user has performed the recommended maintenance, a no-charge repair or replacement will be made to the original owner within one year of the date of purchase. This applies to all repairable instruments which have not been tampered with or damaged. This warranty does not cover consumable items such as batteries, tips and fuses, nor physical damage and wear to components such as probes, sensors and adaptors. For repair service send your tool to the factory address on the back of the Owner's Manual. Repaired or replaced tools will carry a 90-day warranty.

Table of Contents

General description	p. 4
Measuring DC Current	p. 6
Measuring DC Voltage	p. 8
Measuring Resistance	p. 8
Special Features	p. 9
Maintenance	p. 10
Specifications	p. 11

General Description

The AC1000 Clamp-on Connectionless Ammeter is designed for automotive and all other DC applications. More than just an ammeter, the AC1000 is also a high impedance voltmeter and an ohmmeter. No connections are necessary when measuring current, the inductive pick-up simply clamps around any single conductor. Precision readings from 0-1200 amps. Check starters, alternators, generators, voltage regulators, DC motors, MIG welders, plating baths, etc...

Features

- * Measures DC amps, volts & ohms
- * High Input Impedance protects computer circuits
- * Amps zero adjustment
- * Memory button to lock in readings
- * Measures currents up to 1200A
- * Measures current in insulated wires
- * Permits measurements in live circuits
- * Indicates current flow direction
- * High contrast LCD readout
- * Low battery indication
- * Made in U.S.A.

The AC1000 Digital Clamp-on Connectionless Ammeter

Fig. 1

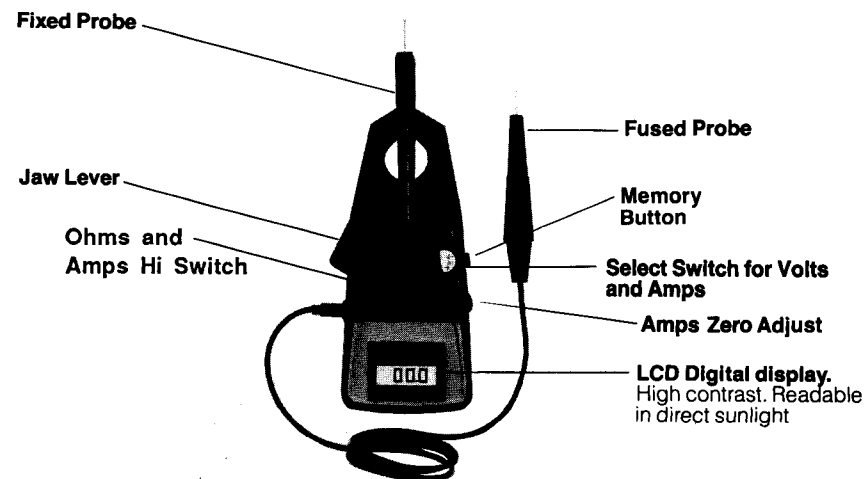

OPERATING INSTRUCTIONS

Measuring DC Current

Two amps ranges are provided. The low range measures current from 0-200 amps with a .1 amp resolution, the high range measures 0-1200 amps with a 1 amp resolution. When first switched on the unit is in the low range; the high range is activated by the "Amps Hi" button on the front of the instrument. **NOTE:** Although the display will read up to 1999, the accurate range of the AC1000 is only up to 1200A. ANY NUMBER DISPLAYED ABOVE 1200 IS INACCURATE AND SHOULD BE TAKEN AS AN OVERRANGE INDICATION.

6

To turn the unit on, rotate the select switch to the "A" position. Check that the display reads zero. If it does not (because of external magnetic fields), adjust the amps zero accordingly.

Encircle a **single** wire in which you wish to measure current. (If more than one wire is in the jaw readings will be inaccurate or non-existent). Make certain the wire is not too large to prevent the jaws from closing properly.

DC amps are now displayed. If the measured current is in excess of 200 amps (indicated by

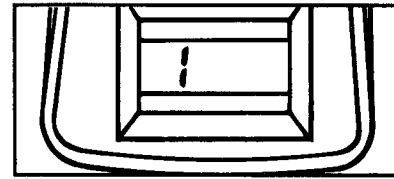

Fig. 2 Overrange Indication

an overrange symbol, see Fig. 2) the amps high range must be used. To do this, depress the "Amps Hi" button on the front of the instrument (see Fig. 1); current can now be measured up to 1200 amps.

Direction of Current Flow

By convention, current flows from + to -. The front of the instrument jaws is marked + and the back is marked -. If the instrument jaws are clamped on

the cable so that current flow is from + to - the display will read "positive." If the flow is from - to + (as marked on the jaws) the display will read "negative."

When working on automobile systems it is recommended that the - sign on the jaw face the battery; this will then make it instantly clear whether current is flowing into (charge) or out of (drain) the battery.

7

Measuring DC Voltage

The AC1000 is equipped with a high impedance (10 megohm) voltmeter safe for modern automobile computer circuitry.

Attach the fixed probe and the fused probe as shown in Fig. 1. Turn the instrument on by rotating the select switch to the "V/ Ω " position. Touch the probes to the circuit to be measured, making firm contact. Voltage is now displayed; a voltage above 199.9 volts will be indicated by the overrange symbol (Fig. 2).

Measuring Resistance

CAUTION: Always disconnect power from circuit and make certain any capacitors are fully discharged before attempting to measure resistance. Failure to do so may result in instrument damage.

Attach fixed and fused probes as shown in Fig. 1. Turn on instrument by rotating the select switch to the "V/ Ω " position. Connect probes to resistance to be measured, insuring good metal to metal contact. Press "Ohms" button (see Fig. 1) on front of instrument. Resistance in ohms is now displayed. Either an open circuit or a resistance

greater than 1999 ohms will cause an overrange indication (see Fig. 2) on the display.

NOTE: Even slight corrosion on the probe tips will decrease accuracy of the AC1000 resistance measurements. Use fine steel wool to clean probe tips on a regular basis.

Special Features

Memory Hold

The AC1000 is equipped with a memory hold button which allows the user to "lock" the display until the button is released. If, for example, a measurement is being taken in a location which makes it difficult or impossible to see the display, the memory hold button can be depressed and the reading presently on the screen will be "held" until the button is released. This will enable the user to remove the instrument from the wire so that he can read the display.

Low Battery Indicator

When battery voltage reaches 8.4V, the low battery indicator will come on. Low battery is indicated by the appearance of a small "LB" on the left side of the display (see Fig. 3).

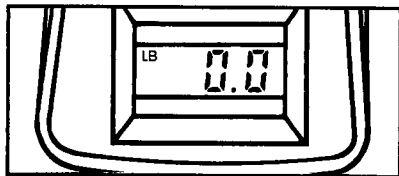

Fig. 3

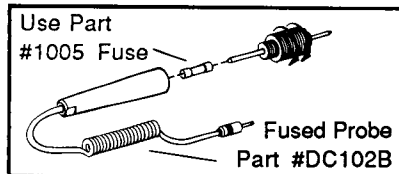

Fig. 4

Maintenance

The AC1000 is essentially maintenance free. What follows are instructions for fuse and battery replacement.

Fuse Replacement

One 1A fuse is located in the fused probe to protect the instrument's circuit board from missapplication. To replace fuse, unscrew the two sections of the probe as shown in Fig. 4. Use only part number 1005 replacement fuses.

Battery Replacement

This unit is powered by one 9 volt transistor battery and one "AAA" cell. Remove the back cover and replace.

Replacement Parts

- Fixed Probe.....Part #DC101
- Fused Probe.....Part #DC102B
- Carrying Case.....Part #1254
- Fuses (Pkg. of 6).....Part #1005

Specifications

Function	Range	Resolution	Accuracy
Amps Low	0-200	.1 Amp	±1%, ±1 digit
Amps High	0-1200	1 Amp	(0-800A) ±1%, ±1digit (800-1200A) +0% to -5%
Volts	0-200	.1 Volt	±1%, ±1 digit
Ohms	0-2000	1 Ohm	±3%, ±1 digit

Operating Temperature Range:

40-105 degrees F.

Maximum Diameter of Cable:

0.84 inches

Weight:

8.5 ounces

Dimensions:

7.5" x 3" x 1.5"

Note

The AC1000 Digital Clamp-on is a highly sensitive instrument which measures current by measuring the magnetic field built up around a conductor. If any strong magnetic fields are present, the accuracy of the instrument may be affected.